



ARMORED PUSHBUTTON SWITCH SEALING BOOTS FOR HIGH-PRESSURE & TEMPERATURE WASHDOWNS & ROUGH HANDLING

APM's HEXSEAL® stainless steel armored pushbutton switch sealing boots, embedded with an elastomeric bladder type membrane, are the best defense against destructive forces of high water pressure and high temperature. They can be used wherever high-pressure washdowns are required; industrial, food, beverage and commercial processing; marine, transportation and off-road equipment cleaning are typical examples. Prolonged switch life and reliability will be greatly enhanced to 100,000-plus actuations and these armored boots are rugged enough to resist rough gloved handling — another important consideration.

TYPICAL APPLICATIONS

- Food & Beverage Processing
- Meat & Dairy Packing
- Medical Equipment
- Pharmaceutical Processing
- Petrochemical Processing
- Construction Equipment
- Marine & Automotive
- Transportation Equipment

FEATURES

- IP66 & 68 Ingress Rated
- Seals Against Hostile Dirty Environments
- 100,000-plus Actuations
- Rugged Stainless Steel Armor
- Ideal for High-Temperature Washdowns
- Standard Silicone Rubber Bladder Seal or *Optional Fluorosilicone (for high concentration of petroleum or other fuel environments)
- Designed to meet MIL-DTL-5423 Specifications

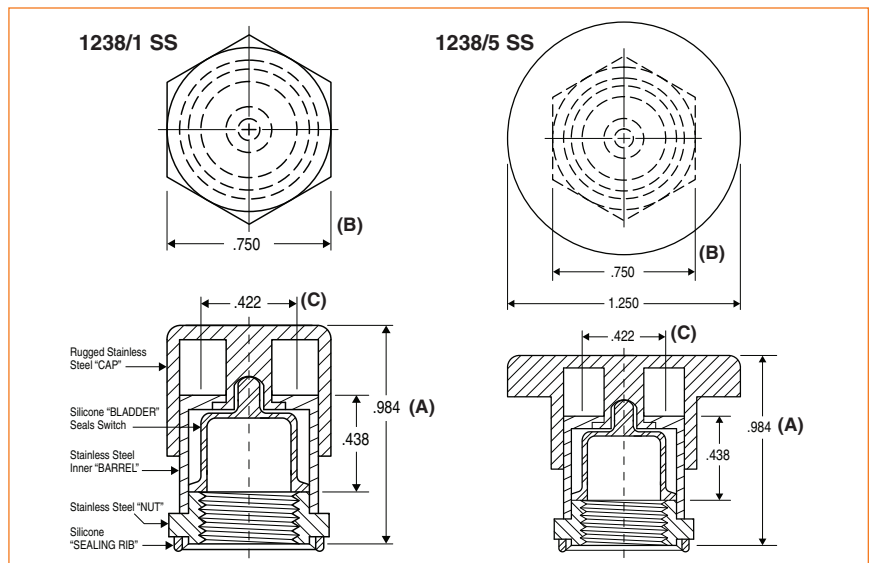

Visit our website for downloadable PDFs & CAD drawings.

Dimensions

Thread Size	Plunger Height		A		B (Flat)		C (I.D.)		APM Boot Part Number	Color	HEXSEAL
	inch	mm	inch	mm	inch	mm	inch	mm			
15/32-32NS-2B	.438	11.11	.984	25.00	.750	19.05	.422	10.72	1238/1 SS	††	•
15/32-32NS-2B	.438	11.11	.984	25.00	.750	19.05	.422	10.72	1238/5* SS	††	•

*P/N 1238/5 features a 1/4" diameter actuator button.

††Stainless steel housing with silicone boot.

SPECIFICATIONS

- Mates With:** 15/32-32 Pushbutton Switch Bushing Threads
- Material:** Series 300 stainless steel armored exterior. Membrane conforms to A-A-59588 Class 3B, Grade 50 unless otherwise specified
- Mounting Nut:** Series 300 stainless steel
- Temperature Range:** -80°F to +400°F (-62°C to +204°C)
- Pressure Range:** Exceeds 15 psi (1 bar) internal and 1,500 psi (103 bar) external
- Operational Life:** 100,000 actuations (minimum)
- Enclosure Protection:** UL/NEMA 4X/6P; IEC60529 IP66/68 Ingress Rated
- Agency Recognition:** UL & ULC Recognized Component to UL Std. 50
- Shelf Life:** Excess of 25 years
- Resistant To:** Salt spray, sunlight, ozone, weather, fungus, and most acids and most detergents (and lubricating oils*)



44 Honeck Street, Englewood NJ 07631
 Tel: (201) 569-5700 • Toll Free: (800) 498-9034
 Fax: (201) 569-4106

www.apmhhexseal.com • Email: info@apmhhexseal.com

