

Sealed Switch Panel Mounting Hole Bushing Seal

Protect Against & Prevent Seepage/Leakage Through Switch Panel Cutout

These reusable self-sealing washers are designed for use with popular sealed switches and circuit breakers. While such sealed switches are designed to tolerate hostile environments (such as salt spray, wash-downs, lubricating fluids, weather, dust and other contaminants) that may compromise reliable switch operation, *they typically do not seal the panel cutout in which they are mounted.* Hence, these same contaminants may "leak past" the bushing through the panel cutout causing equipment/system failures.

Designed to prevent such leakage, each is fabricated from a stainless steel washer with a bonded high-tear strength silicone rubber sealing ring. The soft resilient ring conforms to the panel surface to seal out harmful contaminants.

- Meets IEC IP66/68 enclosure protection.
- UL Recognized for Type 4X & Type 6 enclosure protection.
- Seals the panel cutout in which the circuit breaker is mounted, protecting behind-panel components from dirt/moisture. No O-ring required.
- Reusable in the event the switch or circuit breaker fails and replacement is needed.
- Easy to install without the need for special tools, sealing compounds, sealing tapes, et al.
- Does not compromise switch or circuit breaker performance.
- Meets stringent Military, UL and Canadian National Standards regarding environmental requirements for electrical enclosures.

SPECIFICATIONS

MaterialStainless steel with bonded silicone rubber conforms to A-A-59588 GR. 50 (both sides P/N 60064; one side only P/N 60225)

Temperature Range.....-94°F to +400°F (-70°C to +204°C)

MountingEither Front or Behind Panel

Shelf LifeIn excess of 25 years

Resistant to.....Salt spray, sunlight, ozone, weather, fungus, and most acids and lubricating oils

Agency Recognition...UL-Recognized Component to UL Std. 50, Types 1, 2, 3(R)(S), 4(X), 6, 12 & 13. UL Recognition also includes compliance with Canadian National Standards.

HOW TO ORDER

Specify selected APM boot part number shown in chart below.

| APM Part Number | Compatible Switch Bushing | Washer Diameter | Washer Thickness | Color | Conforms to* |
|-----------------|---------------------------|------------------|------------------|-------|--|
| 60064 60225 | 15/32-32 | 0.677" 0.660" | 0.120" 0.105" | Gray | Meets MIL-B-5423/16-01, MS25196, UL & ULC Recognized |

*APM's policy is to manufacture our HEXSEAL® sealing boots as defined by the requirements of MIL-Spec B-5423 which we regard as the standard for the switch, circuit breaker and potentiometer industry. These requirements were formulated based on our original patent.

Note: Where the possibility of ice build-up or other contaminants can accumulate in the toggle breaker external actuating mechanism, we recommend using a full silicone sealing boot which will protect the actuator mechanism and keep it operating smoothly, and its perimeter seal will protect the mounting hole from potential seepage.

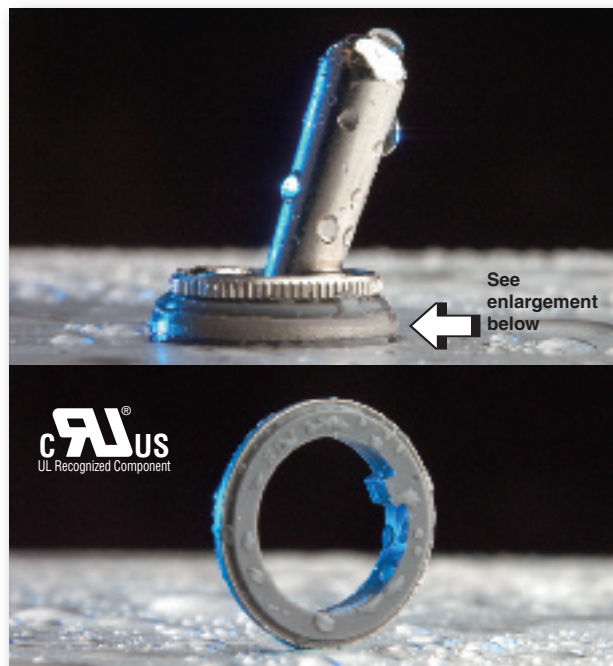
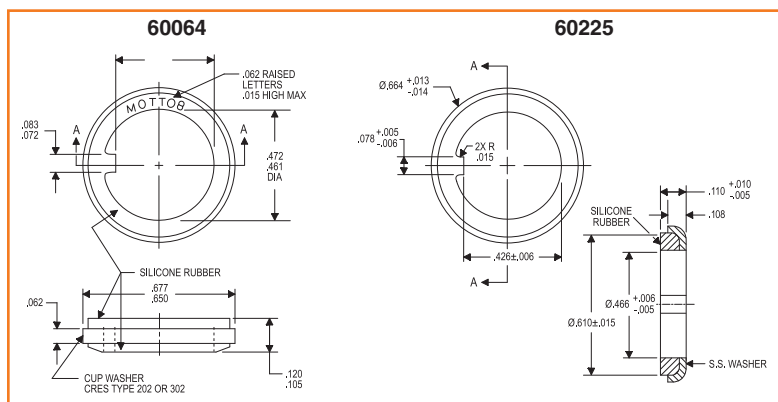

Visit our website for dimensional drawings and to download CAD drawings.

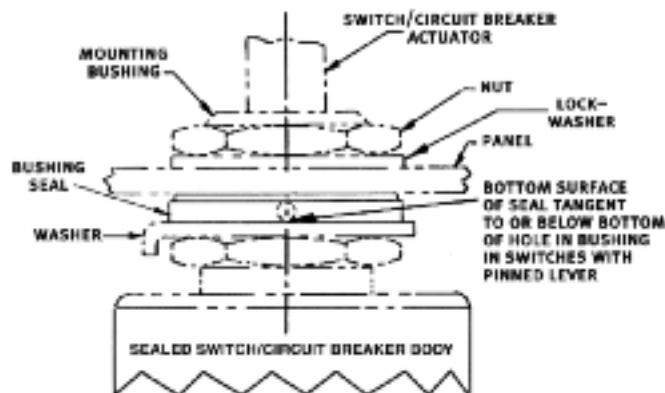

44 Honeck Street, Englewood NJ 07631
 Tel: (201) 569-5700 • Toll Free: (800) 498-9034
 Fax: (201) 569-4106

www.apmhexseal.com • Email: info@apmhexseal.com

